



Chapter 10 Rotation of a rigid object about a fixed axis-I

簡紋濱

國立交通大學 理學院 電子物理系

CONTENTS

1. Angular Position, Velocity, and Acceleration
2. Rotational Kinematics
3. Angular and Translational Quantities
4. Rotational Kinetic Energy
5. Calculation of Moments of Inertia
6. Torque
7. The Rigid Body Under a Net Torque
8. Rotational Energy
9. Rolling Motion

1. ANGULAR POSITION, VELOCITY, AND ACCELERATION

Rigid body: Not elastic & no relative motion for elements in the body

Rotation: Given an axis, moving around the fixed axis

Angular Position: $\theta = s/r$, 1 rev = 360° (deg) = 2π (rad), 1 rad = 57.3°

Angular Displacement: $\Delta\theta = \theta_2 - \theta_1$

Here the counterclockwise direction is positive.

Average Angular Velocity: $\omega_{avg} = \frac{\Delta\theta}{\Delta t} = \frac{\theta_2 - \theta_1}{t_2 - t_1}$

Instant Ang Vel: $\omega = \lim_{\Delta t \rightarrow 0} \frac{\Delta\theta}{\Delta t} = d\theta/dt$,

Unit: rpm – rev per min

Average Angular Accel: $\alpha_{avg} = \frac{\Delta\omega}{\Delta t} = \frac{\omega_2 - \omega_1}{t_2 - t_1}$

Instant Angular Accel: $\alpha = \lim_{\Delta t \rightarrow 0} \frac{\Delta\omega}{\Delta t} = \frac{d\omega}{dt}$

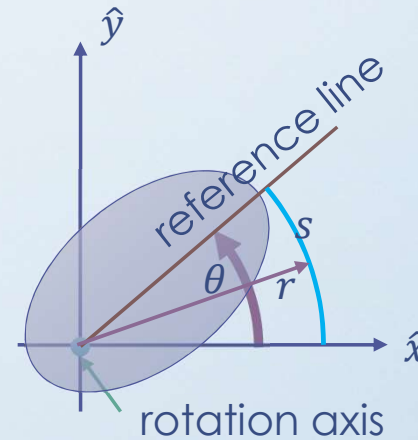

1. ANGULAR POSITION, VELOCITY, AND ACCELERATION

Example: A disk is rotating about its central axis like a merry-go-round. The angular position $\theta(t)$ of a reference line on the disk is given by $\theta(t) = -1.00 - 0.600t + 0.250t^2$ with t in seconds, θ in radians. (a) At what time does $\theta(t)$ reach the minimum value? What's that value? (b) Calculate the angular velocity at any time t . Calculate the average angular velocity from $t=-3.0$ to $t=6.0$ s.

$$(a) \quad \frac{d\theta}{dt}_{t=t_{min}} = 0 \rightarrow -0.600 + 0.500t_{min} = 0 \rightarrow t_{min} = 1.2 \text{ (s)}$$

$$\theta_{min} = -1.00 - 0.600 \times (1.2) + 0.250 \times (1.2)^2 = -1.36 \text{ (rad)}$$

$$(b) \quad \omega(t) = \frac{d\theta}{dt} = -0.600 + 0.500t$$

$$\omega_{avg} = \frac{\theta(6.0) - \theta(-3.0)}{6.0 - (-3.0)} = \frac{4.4 - 3.05}{9} = 0.15 \left(\frac{\text{rad}}{\text{s}}\right)$$

2. ROTATIONAL KINEMATICS

A Comparison of Equations for Rotational & Translational Motion

Motion in constant velocity:

$$\omega = \omega_0$$

$$v = v_0$$

$$\theta = \theta_0 + \omega_0 t$$

$$x = x_0 + v_0 t$$

Motion in constant acceleration:

$$\omega = \omega_0 + \alpha t$$

$$v = v_0 + at$$

$$\theta = \theta_0 + \omega_0 t + \frac{1}{2} \alpha t^2$$

$$x = x_0 + v_0 t + \frac{1}{2} at^2$$

$$\omega^2 = \omega_0^2 + 2\alpha(\theta_f - \theta_i)$$

$$v^2 = v_0^2 + 2a(x_f - x_i)$$

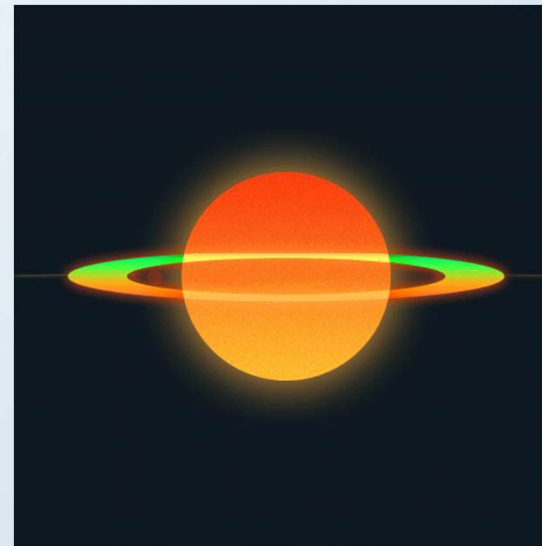

2. ROTATIONAL KINEMATICS

Example: A grindstone rotates at constant angular acceleration $\alpha = 0.35 \text{ rad/s}^2$. At time $t = 0$, it has an angular velocity of $\omega_0 = -4.6 \text{ rad/s}$ and a reference line on it is horizontal, at the angular position $\theta_0 = 0$. Please calculate its angular velocity and angular position.

$$\alpha = 0.35, \text{ at } t = 0, \omega_0 = -4.6, \theta_0 = 0$$

$$\omega(t) = -4.6 + 0.35t$$

$$\theta(t) = 0 - 4.6t + 0.175t^2$$

3. ANGULAR AND TRANSLATIONAL QUANTITIES

Link The Angular Variables to Translational Variables

The Angular Displacement: $s = r\theta$

The Angular Velocity: $v = r\omega, T = 2\pi r/v$

The Acceleration: $a_t = r\alpha, a_r = r\omega^2 = v^2/r$

Example: The centrifuge is used to accustom astronaut trainees to high accelerations.

The radius of the circle traveled by an astronaut is 15.0 m.

(a) At what constant angular speed must the centrifuge rotate if the astronaut is to have a linear acceleration of magnitude 11g? (b) What is the tangential acceleration of the astronaut if the centrifuge accelerates at a constant rate from rest to the angular speed of (a) in 120 s?

$$11 \times 9.8 = \frac{v^2}{15} = 15\omega^2 \rightarrow \omega = \sqrt{\frac{11 \times 9.8}{15.0}} = 2.68 \text{ (rad/s)}$$

$$a_t = r\alpha = 15.0 \frac{2.68 - 0}{120} = 0.34 \text{ (m/s}^2\text{)}$$

4. ROTATIONAL KINETIC ENERGY

Kinetic Energy

$$K = \sum_{i=1}^N \frac{m_i v_i^2}{2}, \quad v_i = r_i \omega$$

$$K = \frac{1}{2} \sum_{i=1}^N m_i r_i^2 \omega^2 \rightarrow I = \sum_{i=1}^N m_i r_i^2$$

I : rotational inertia

$$K = \frac{1}{2} I \omega^2$$

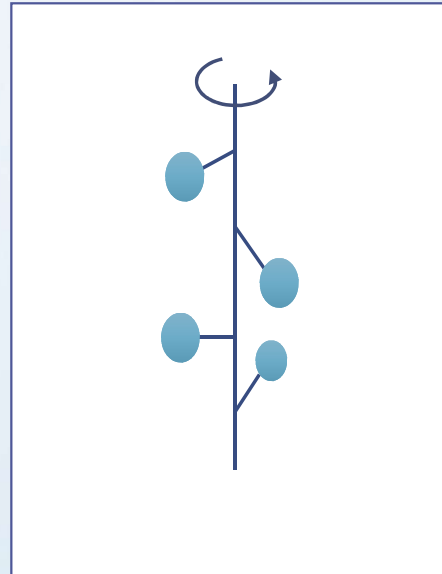

4. ROTATIONAL KINETIC ENERGY

Example: Consider an oxygen molecule rotating on the xy plane about the z axis. The rotation axis passes through the center of the molecule, perpendicular to its length. The mass of each oxygen atom is 2.66×10^{-26} kg, and the average separation between the two atoms is $d = 1.21 \times 10^{-10}$ m. (a) Calculate the moment of inertia of the molecule about the z axis. (b) If the angular speed of the molecule about the z axis is 4.60×10^{12} rad/s, what is its rotational kinetic energy?

$$(a) \quad I = \sum m_i r_i^2 = 2 \times 2.66 \times 10^{-26} \times (0.605 \times 10^{-10})^2$$

$$I = 1.95 \times 10^{-46} \text{ (kg m}^2\text{)}$$

$$(b) \quad K = \frac{I\omega^2}{2} = 2.06 \times 10^{-2} \text{ (J)} = 12.9 \text{ (meV)}$$

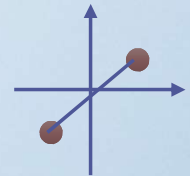

4. ROTATIONAL KINETIC ENERGY

Example: Please calculate the moment of inertia of the four objects if the rotation is about the z axis and about the y axis.

About the Z axis:

$$I_z = \sum m_i r_i^2 = 2ma^2 + 2Mb^2$$

About the y axis:

$$I_y = \sum m_i r_i^2 = 2Mb^2$$

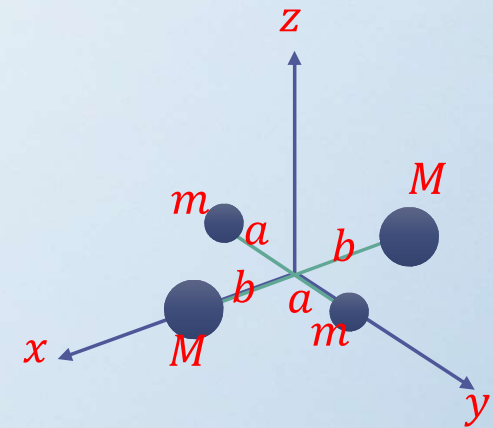

CONTENTS

1. Angular Position, Velocity, and Acceleration
2. Rotational Kinematics
3. Angular and Translational Quantities
4. Rotational Kinetic Energy
5. Calculation of Moments of Inertia
6. Torque
7. The Rigid Body Under a Net Torque
8. Rotational Energy
9. Rolling Motion

5. CALCULATION OF MOMENTS OF INERTIA

Cartesian Coordinate: x, y, z

$$dV = dx dy dz$$

$$V = \int_0^c \int_0^b \int_0^a dx dy dz = abc$$

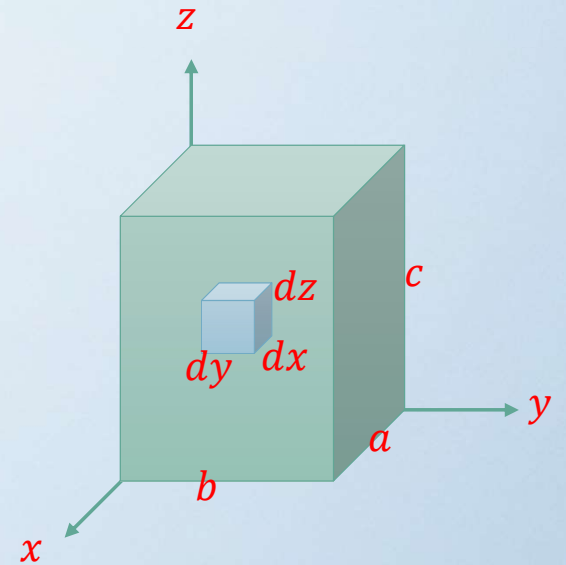

5. CALCULATION OF MOMENTS OF INERTIA

Cylindrical Coordinate:

$$dV = r d\theta dr dz$$

$$V = \int_0^H \int_0^R \int_0^{2\pi} r d\theta dr dz = \pi R^2 H$$

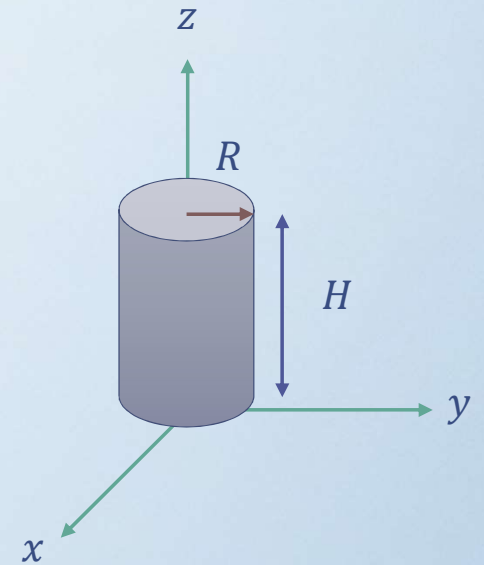
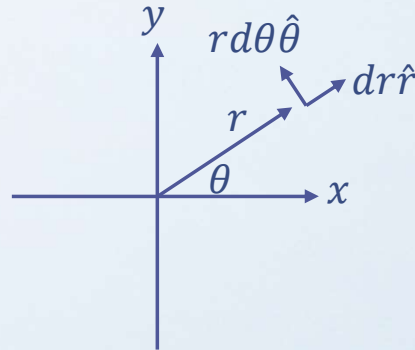

5. CALCULATION OF MOMENTS OF INERTIA

Spherical Coordinate:

$$dV = (r \sin \theta d\phi)(r d\theta)(dr)$$

$$V = \int_0^R \int_0^\pi \int_0^{2\pi} r^2 \sin \theta d\phi d\theta dr$$

$$V = \int_0^R \int_0^\pi r^2 \sin \theta [\phi]_0^{2\pi} d\theta dr$$

$$V = 2\pi \int_0^R r^2 [-\cos \theta]_0^\pi dr$$

$$V = 4\pi \int_0^R r^2 dr = \frac{4\pi}{3} R^3$$

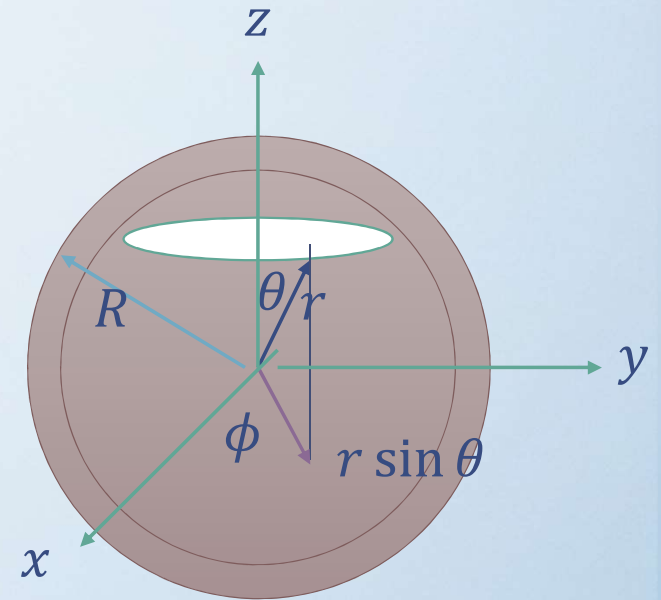

5. CALCULATION OF MOMENTS OF INERTIA

Moments of Inertia of a Hoop

$$M = 2\pi R\lambda \quad \lambda = \frac{M}{2\pi R}$$

$$I = \sum m_i r_i^2 = \int_0^{2\pi} R^2 \lambda R d\theta = MR^2$$

Moments of Inertia of an Annular Cylinder

$$M = \sigma\pi(R_2^2 - R_1^2) \quad \sigma = \frac{M}{\pi(R_2^2 - R_1^2)}$$

$$I = \int_{R_1}^{R_2} \int_0^{2\pi} r^2 \sigma r d\theta dr = \frac{M}{2} (R_2^2 + R_1^2)$$

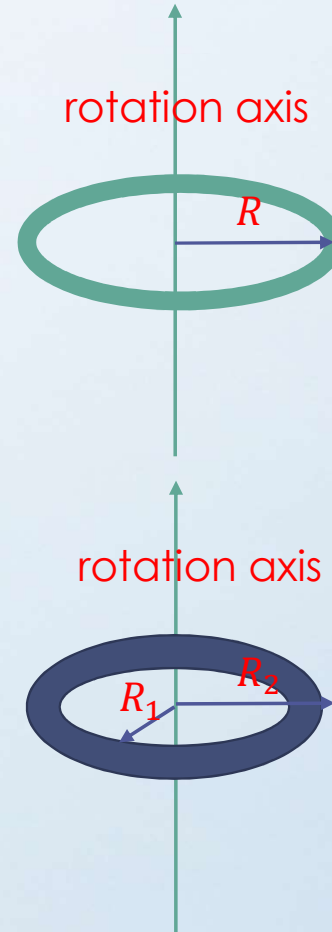

<https://giphy.com/gifs/weight-pt0EKLDJmVvIS>

5. CALCULATION OF MOMENTS OF INERTIA

$$M = \sigma \pi (R^2) \quad \sigma = \frac{M}{\pi R^2}$$

$$I = \int_0^R \int_0^{2\pi} r^2 \sigma r d\theta dr = \frac{MR^2}{2}$$

$$M = \rho \pi R^2 L \quad \rho = \frac{M}{\pi R^2 L}$$

$$I = \int_{-L/2}^{L/2} \int_0^R \int_0^{2\pi} (z^2 + r^2 \sin^2 \theta) \rho r d\theta dr dz$$

$$I = \frac{MR^2}{4} + \frac{ML^2}{12}$$

$$R \ll L \quad I = \frac{ML^2}{12}$$

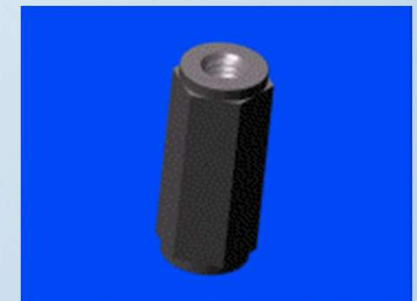
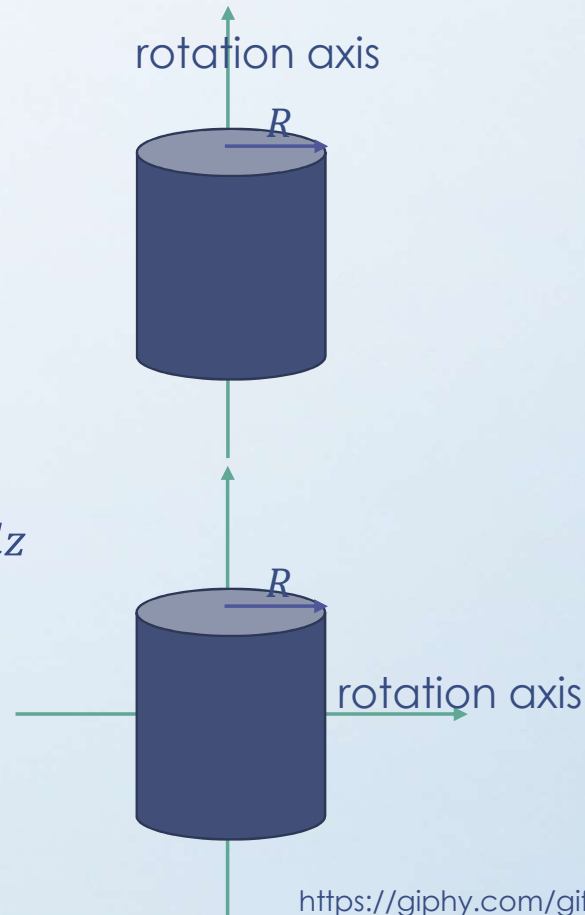

<https://giphy.com/gifs/ugo-red-bull-3oxQNdrBtmnUYiS664>
 Moments of Inertia of a <https://giphy.com/gifs/302-nrlgxjZWCWim8>

5. CALCULATION OF MOMENTS OF INERTIA

Moments of Inertia of a Sphere

$$M = \frac{4\pi R^3}{3} \rho \quad \rho = \frac{3M}{4\pi R^3}$$

$$I = \int_0^R \int_0^\pi \int_0^{2\pi} r^2 \sin^2 \theta \rho r^2 \sin \theta d\phi d\theta dr$$

$$I = 2\pi\rho \int_0^R \int_0^\pi r^4 \sin^3 \theta d\theta dr$$

$$\int_0^\pi \sin^3 \theta d\theta = \int_0^\pi (\cos^2 \theta - 1) d(\cos \theta) = \left[\frac{\cos^3 \theta}{3} - \cos \theta \right]_{\theta=0}^{\theta=\pi} = \frac{4}{3}$$

$$I = \frac{8\pi\rho}{3} \int_0^R r^4 dr = \frac{8\pi\rho R^5}{3 \cdot 5} = \frac{2MR^2}{5}$$

Moments of Inertia of a Spherical Shell

$$M = 4\pi R^2 \sigma \quad \sigma = \frac{M}{4\pi R^2}$$

$$I = \int_0^\pi \int_0^{2\pi} \sigma R^2 \sin^2 \theta R^2 \sin \theta d\phi d\theta = \frac{2MR^2}{3}$$

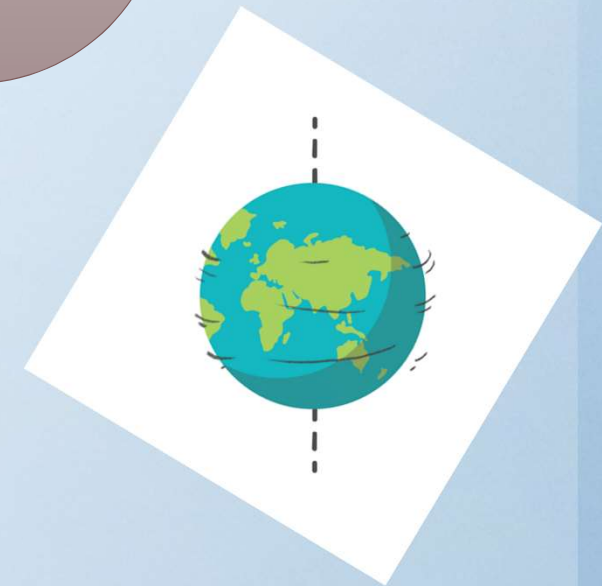
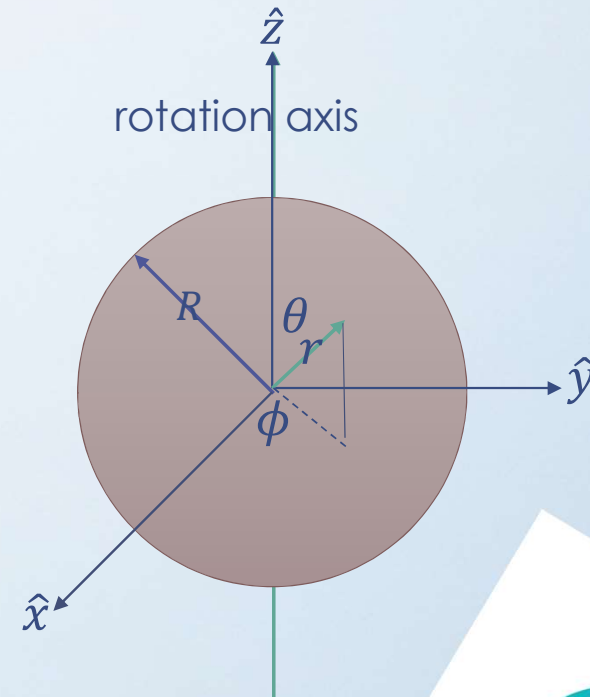

5. CALCULATION OF MOMENTS OF INERTIA

Moments of Inertia of a Slab

$$M = \rho abc \quad \rho = \frac{M}{abc}$$

$$I = \int_{-c/2}^{c/2} \int_{-b/2}^{b/2} \int_{-a/2}^{a/2} (x^2 + y^2) \rho dx dy dz = \frac{M(a^2 + b^2)}{12}$$

$$I = \int_{-c/2}^{c/2} \int_{-b/2}^{b/2} \int_{-a/2}^{a/2} (x^2 + y^2) \frac{M}{abc} dx dy dz = \frac{M(a^2 + b^2)}{12}$$

$$I = \int_{-b/2}^{b/2} \int_{-a/2}^{a/2} (x^2 + y^2) \frac{M}{ab} dx dy = \frac{M(a^2 + b^2)}{12}$$

$$M = \sigma ab \quad \sigma = \frac{M}{ab}$$

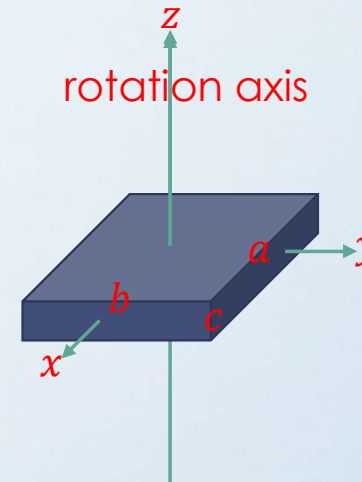

5. CALCULATION OF MOMENTS OF INERTIA

Parallel Axis Theorem

Restriction: Shift of Rotation Axis from That Through The COM to a New Position

Simplify The Derivation: Let COM at O

$$x_{COM} = \frac{\sum_{i=1}^N m_i x_i}{M} = 0 \quad y_{COM} = \frac{\sum_{i=1}^N m_i y_i}{M} = 0$$

$$I_{COM} = \sum m_i (x_i^2 + y_i^2) = \int (x^2 + y^2) dm$$

$$\begin{aligned} I_P &= \sum m_i ((x_i - a)^2 + (y_i - b)^2) \\ &= \sum m_i (x_i^2 + y_i^2) - 2a \sum m_i x_i - 2b \sum m_i y_i + (a^2 + b^2) \sum m_i \end{aligned}$$

$$I_P = I_{COM} + M(a^2 + b^2) = I_{COM} + Md^2$$

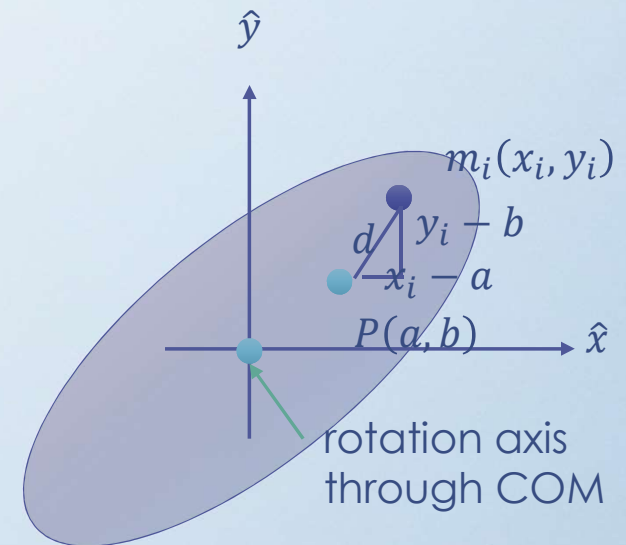

5. CALCULATION OF MOMENTS OF INERTIA

Example: Four objects with indicated masses are arranged as shown in the figure. What's the rotational inertia about the z axis through its center of mass? What's the rotational inertia about an axis through the mass m and parallel to the first axis?

$$I_{COM} = 2ma^2 + 2Mb^2$$

$$I = 2M(a^2 + b^2) + m(2a)^2$$

$$I = I_{COM} + (2M + 2m)a^2$$

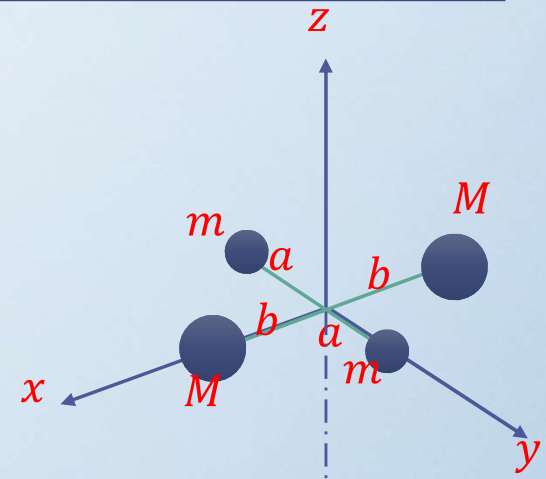

5. CALCULATION OF MOMENTS OF INERTIA

Example: A uniform rod of length L and mass M is free to rotate on a frictionless pin through one end. The rod is released from rest in the horizontal position. What is the angular speed of the rod at its lowest position?

$$I_{COM} = \frac{ML^2}{12} \quad I_{pivot} = I_{COM} + M\left(\frac{L}{2}\right)^2 = \frac{ML^2}{3}$$

$$I = \frac{MR^2}{4} + \frac{ML^2}{12}$$

$$K_1 + U_1 = K_2 + U_2$$

$$0 + Mg\left(\frac{L}{2}\right) = \frac{1}{2}I_{pivot}\omega^2 + 0$$

$$\omega = \sqrt{\frac{3g}{L}}$$

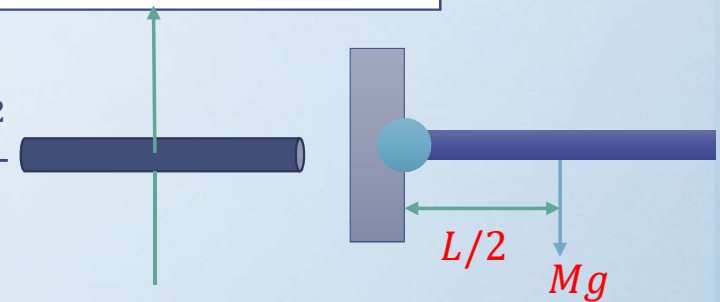

6. TORQUE

Torque: Like a Force, Used to Accelerate The Angular Displacement, it is defined as $\vec{\tau} = \vec{r} \times \vec{F}$

Example: What's the net torque on the cylinder for the rotational motor shown in the figure?

$$\vec{\tau} = \vec{r}_1 \times \vec{F}_1 + \vec{r}_2 \times \vec{F}_2$$

$$\vec{\tau} = -r_1 F_1 \hat{k} + r_2 F_2 \hat{k}$$

$$\vec{\tau} = (r_2 F_2 - r_1 F_1) \hat{k}$$

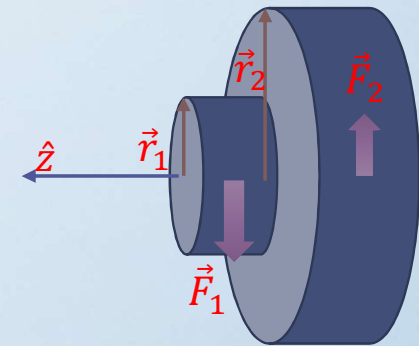

CONTENTS

1. Angular Position, Velocity, and Acceleration
2. Rotational Kinematics
3. Angular and Translational Quantities
4. Rotational Kinetic Energy
5. Calculation of Moments of Inertia
6. Torque
7. The Rigid Body Under a Net Torque
8. Rotational Energy
9. Rolling Motion

7. THE RIGID BODY UNDER A NET TORQUE

Reaction to The Net Torque:

$$\vec{\tau}_{net} = \sum \vec{\tau}_i = \sum \vec{r}_i \times \vec{F}_i = \vec{R} \times \vec{F}_t$$

$$\vec{F}_t = m\vec{a}_t, a_t = R\alpha, F_t = mR\alpha$$

$$\vec{\tau}_{net} = RF_t\hat{n} = mR^2\alpha\hat{n} = I\alpha\hat{n}$$

$$\tau_{net} = I\alpha$$

7. THE RIGID BODY UNDER A NET TORQUE

Example: A uniform rod of length L and mass M is attached to a frictionless pivot and is free to rotate about the pivot in the vertical plane. The rod is released from rest in the horizontal position. What is the initial angular acceleration?

$$I_{COM} = \frac{ML^2}{12}$$

$$I_{pivot} = I_{COM} + M \left(\frac{L}{2}\right)^2 = \frac{ML^2}{3}$$

$$\tau = I\alpha$$

$$\vec{r} \times \vec{F} = I\vec{\alpha} \rightarrow \frac{L}{2}Mg = \frac{ML^2}{3}\alpha \quad \alpha = \frac{3g}{2L}$$

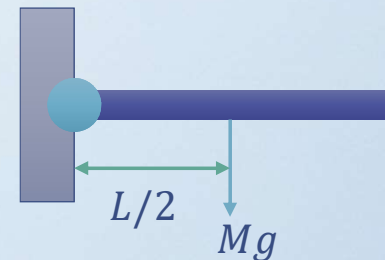

7. THE RIGID BODY UNDER A NET TORQUE

Example: A wheel of radius R , mass M , and moment of inertia I is mounted on a frictionless horizontal axle. A light cord wrapped around the wheel supports an object of mass m . Calculate the angular acceleration of the wheel, the linear acceleration of the object, and the tension in the cord.

$$\tau = I\alpha \quad \rightarrow \quad RT = I\alpha$$

$$mg - T = ma$$

$$a = R\alpha$$

$$a = \frac{mg}{m + \frac{I}{R^2}} \quad \alpha = \frac{1}{R} \frac{mg}{m + \frac{I}{R^2}}$$

$$T = \frac{I}{R} \frac{1}{m + \frac{I}{R^2}} \frac{mg}{R} = \frac{mgI}{I + mR^2}$$

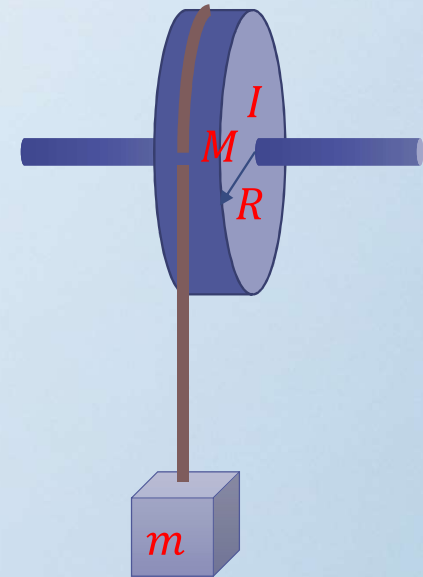

7. THE RIGID BODY UNDER A NET TORQUE

Example: Two blocks having masses m_1 and m_2 are connected to each other by a light cord that passes over two identical frictionless pulleys, each having a moment of inertia I and radius R . Find the acceleration of each block and the tension T_1 , T_2 , and T_3 in the cord.

$$m_1 g - T_1 = m_1 a$$

$$R(T_1 - T_2) = I\alpha$$

$$R(T_2 - T_3) = I\alpha$$

$$T_3 - m_2 g = m_2 a$$

$$R\alpha = a$$

$$a = \frac{(m_1 - m_2)g}{m_1 + m_2 + 2\frac{I}{R^2}}$$

$$T_1 = 2m_1 \left(\frac{m_2 g + \frac{I g}{R^2}}{m_1 + m_2 + 2\frac{I}{R^2}} \right)$$

$$T_3 = 2m_2 \left(\frac{m_1 g + \frac{I g}{R^2}}{m_1 + m_2 + 2\frac{I}{R^2}} \right)$$

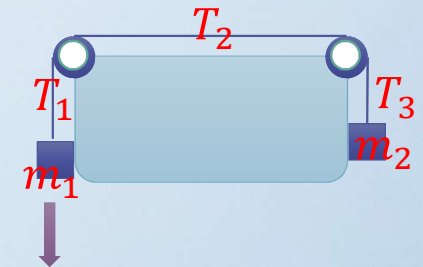

8. ROTATIONAL ENERGY

Work & Work-Kinetic Energy

$$dW = \vec{F} \cdot d\vec{r} = F_t ds = F_t R d\theta = \tau d\theta$$

$$W = \int \tau d\theta = \int I \alpha d\theta = \int d\left(\frac{I\omega^2}{2}\right) = \frac{I\omega_f^2}{2} - \frac{I\omega_i^2}{2}$$

$$P = \frac{dW}{dt} = \tau \frac{d\theta}{dt} = \tau\omega$$

$$W = \int \tau d\theta \quad W = \int F dx$$

$$K = \frac{I\omega^2}{2} \quad K = \frac{mv^2}{2}$$

$$P = \tau\omega \quad P = Fv$$

$$L = I\omega \quad p = mv$$

$$\tau_{net} = dL/dt \quad F_{net} = dp/dt$$

8. ROTATIONAL ENERGY

Example: A uniform rod of length L and mass M is free to rotate on a frictionless pin passing through one end. The rod is released from rest in the horizontal position. Determine the tangential speed of the COM and the tangential speed of the lowest point on the rod when it is in the vertical position.

$$I_{COM} = \frac{ML^2}{12}$$

$$I_{pivot} = I_{COM} + M\left(\frac{L}{2}\right)^2 = \frac{ML^2}{3}$$

$$K_1 + U_1 = K_2 + U_2 \quad 0 + Mg\frac{L}{2} = \frac{1}{2}\frac{ML^2}{3}\omega^2 + 0$$

$$\omega = \sqrt{\frac{3g}{L}} \quad v_{COM} = \frac{L}{2}\omega = \frac{\sqrt{3Lg}}{2}$$

$$v_{end} = L\omega = \sqrt{3Lg}$$

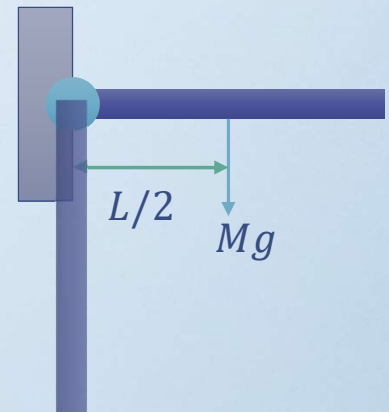

9. ROLLING MOTION

Rolling - Rotational and Translational Motion

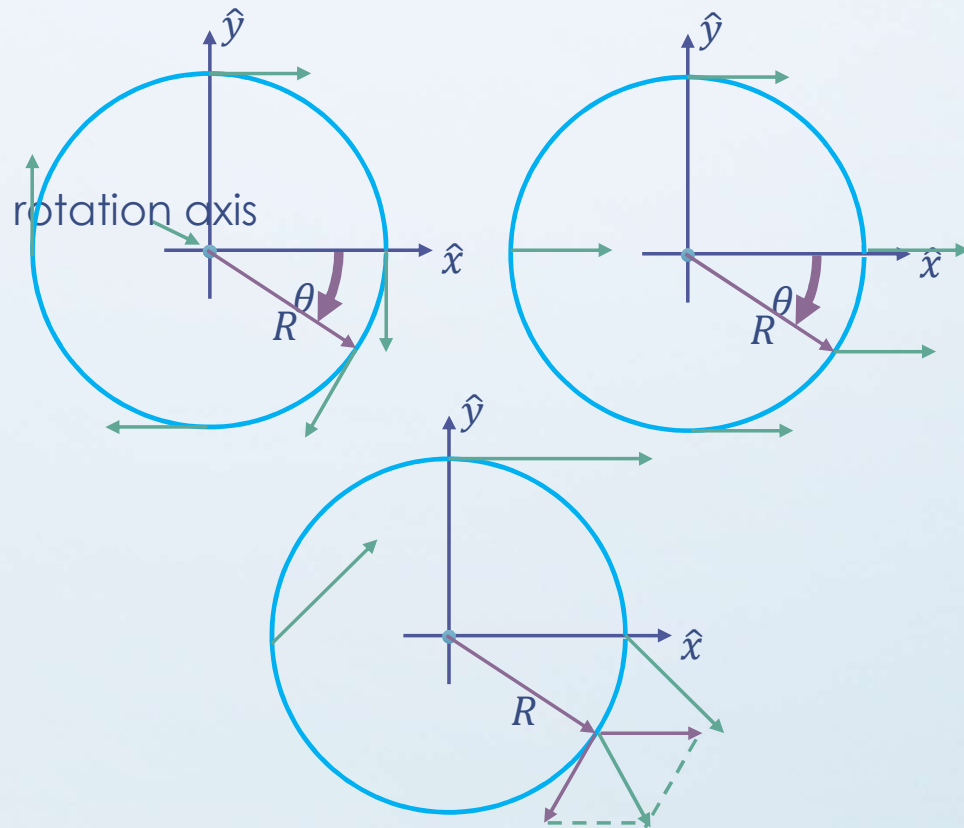

$$v = R\omega, \omega = d\theta/dt$$

$$\vec{r} = R \cos \theta \hat{i} - R \sin \theta \hat{j}$$

$$\vec{v} = -\omega R \sin \theta \hat{i} - \omega R \cos \theta \hat{j}$$

$$\vec{v} = -v \sin \theta \hat{i} - v \cos \theta \hat{j}$$

$$\vec{v}_{COM} = v \hat{i}$$

$$\vec{v}_{net} = (v - v \sin \theta) \hat{i} - v \cos \theta \hat{j}$$

$$\theta = \frac{\pi}{2}, \vec{v}_{net} = 0 \hat{i} + 0 \hat{j}$$

$$\theta = \pi, \vec{v}_{net} = v \hat{i} + v \hat{j}$$

$$\theta = \frac{3\pi}{2}, \vec{v}_{net} = 2v \hat{i} + 0 \hat{j}$$

$$K = K_{COM} + K_{Rotation}$$

$$K = \frac{1}{2} M v_{COM}^2 + \frac{1}{2} I_{COM} \omega^2 = \frac{1}{2} I_{pivot} \omega^2$$

9. ROLLING MOTION

Example: A uniform solid cylindrical disk, of mass $M = 1.4$ kg and radius $R = 8.5$ cm, rolls smoothly across a horizontal table at a speed of 15 cm/s.

What is its kinetic energy?

$$I_{COM} = \frac{MR^2}{2}, M = 1.4, R = 0.085, v_{COM} = 0.15$$

$$I_{pivot} = \frac{MR^2}{2} + MR^2 = \frac{3}{2}MR^2$$

$$K = \frac{1}{2}Mv_{COM}^2 + \frac{1}{2}I_{COM}\omega^2 = \frac{1}{2}I_{pivot}\omega^2$$

$$K = \frac{1}{2}MR^2\omega^2 + \frac{1}{2}\left(\frac{MR^2}{2}\right)\omega^2 = \frac{1}{2}\left(\frac{3MR^2}{2}\right)\omega^2$$

$$K = \frac{1}{2}Mv_{COM}^2 + \frac{1}{4}Mv_{COM}^2 = \frac{3}{4}Mv_{COM}^2 = 0.0236(J)$$

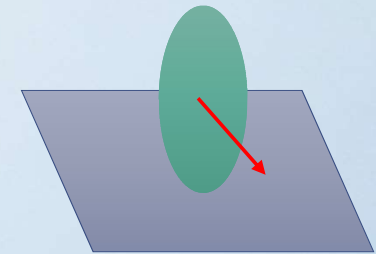

9. ROLLING MOTION

Example: A uniform ball, of mass $M = 6.00$ kg and radius R , rolls smoothly from rest down a ramp at angle $\theta = 30.0^\circ$. (a) The ball descends a vertical height $h = 1.20$ m to reach the bottom of the ramp. What is its speed at the bottom? (b) What are the magnitude and direction of the friction force on the ball as it rolls down the ramp?

$$f_s < f_{s,max} \quad I_{COM} = I_{ball} = \frac{2}{5}MR^2$$

$$Mg \sin \theta - f_s = Ma$$

$$I\alpha = Rf_s$$

$$a = R\alpha$$

$$a = \frac{Mg \sin \theta}{M + \frac{I}{R^2}} = \frac{Mg \sin \theta}{M + \frac{2}{5}M} = \frac{5}{7}g \sin \theta$$

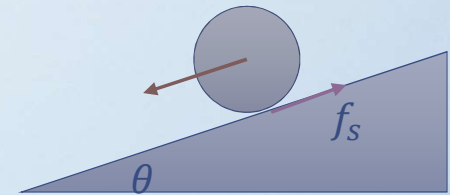

<https://giphy.com/gifs/sparty-finale-X17JzLcx2j0ti>

9. ROLLING MOTION

Example: A uniform ball, of mass $M = 6.00$ kg and radius R , rolls smoothly from rest down a ramp at angle $\theta = 30.0^\circ$. (a) The ball descends a vertical height $h = 1.20$ m to reach the bottom of the ramp. What is its speed at the bottom? (b) What are the magnitude and direction of the friction force on the ball as it rolls down the ramp?

$$(a) \quad Mgh = \frac{1}{2}Mv_{COM}^2 + \frac{1}{2}I_{COM}\omega^2$$
$$I_{COM} = \frac{2}{5}MR^2, v_{COM} = R\omega, Mgh = \frac{7}{10}Mv_{COM}^2$$
$$v_{COM} = \sqrt{\frac{10}{7}gh} = 4.10(\text{m/s})$$

$$(b) \quad a = \frac{5}{7}g \sin \theta$$

$$f_s = Mg \sin \theta - Ma = \frac{2}{7}Mg \sin \theta = 8.40(\text{N})$$

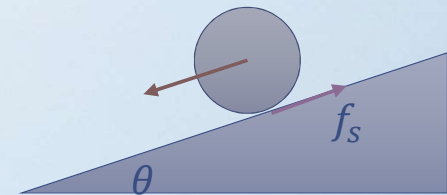

<https://giphy.com/gifs/sparty-finale-X17JzLcx2j0ti>

ACKNOWLEDGEMENT



國立交通大學理學院
自主愛學習計畫



【科技部補助】